

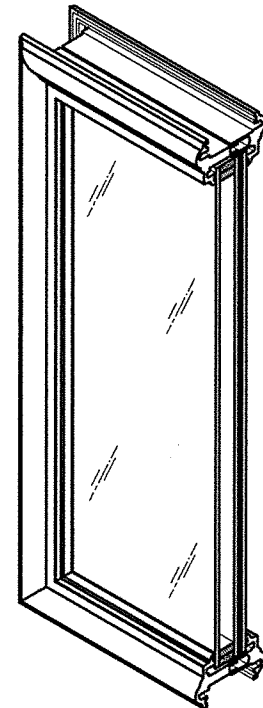

21300 W 8 Mile Rd.
Southfield, MI 48075-5638

"ARMOR-GARD" ALUMINUM DOOR GLASS ASSEMBLY COMPONENT APPROVAL "IMPACT"



LIGHT DETAIL

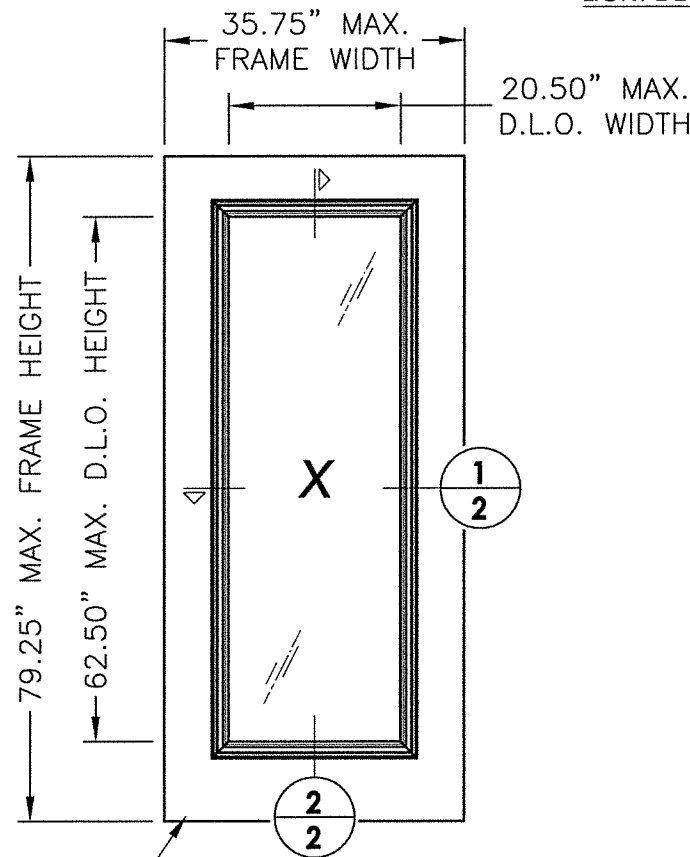

SWING DOOR OR SIDELITE SYSTEM UNDER SEPARATE APPROVAL

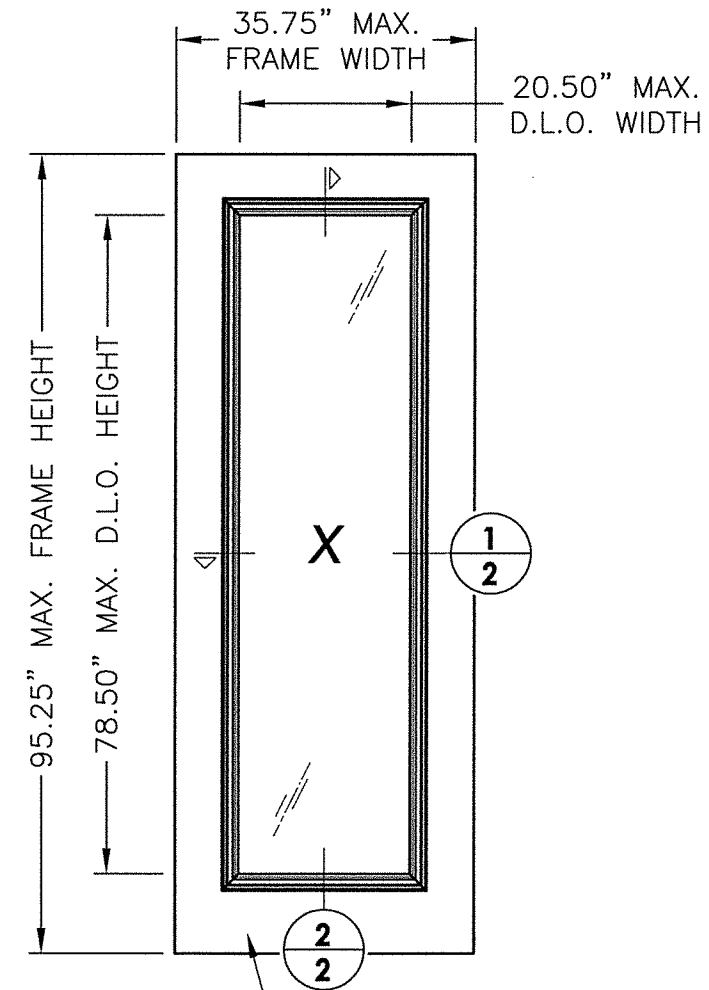

SWING DOOR OR SIDELITE SYSTEM UNDER SEPARATE APPROVAL

DESIGN PRESSURE (PSF)	
POSITIVE	NEGATIVE
+60.0	-60.0

GENERAL NOTES

1. This product has been evaluated and is in compliance with the 6th Edition (2017) Florida Building Code (FBC) structural requirements including the High Velocity Hurricane Zone (HVHZ).
2. This product shall only be used as a substitute doorglass assembly in conjunction with glazed steel or fiberglass side hinged swing doors or fixed sidelites possessing a comparable current Florida Statewide product approval. The lite opening size shall not exceed the opening size approved in the glazed steel or fiberglass side hinged swing doors or fixed sidelites approval. See sheet 2 for door and sidelite panel construction specifications.
3. The design pressure (DP) rating shall be the lesser of the DP rating shown on sheet 1 of this approval or the DP rating shown in the glazed steel or fiberglass side hinged swing doors or fixed sidelites approval being used.
4. When used in areas outside of the "HVHZ" requiring wind borne debris protection this product complies with FBC Sections 1609.1.2 & R301.2.1.2 and does not require an impact resistant covering. This product meets missile level "D" and includes Wind Zone 4 as defined in ASTM E 1996 and FBC Sections 1609.1.2.2 & R301.2.1.2.1.
5. When used in the "HVHZ" this product complies with Section 1626 of the FBC and does not require an impact resistant covering.
6. This product meets the water infiltration requirements for "HVHZ".
7. Aluminum components, including fasteners, shall meet the requirements of FBC Section 2003.

TABLE OF CONTENTS	
SHEET #	DESCRIPTION
1	Typical elevations, design pressures & general notes
2	Cross sections, glazing detail & bill of materials

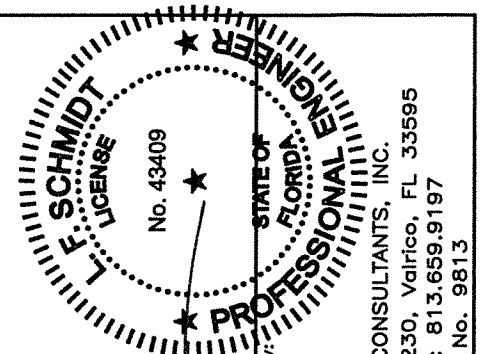

LFS
10.4.17

Documents Prepared By:
Lyndon F. Schmidt
P.E. No. 43409

RW
BUILDING CONSULTANTS, INC.
P.O. Box 230, Vairico, FL 33595
Phone No.: 813.659.9197
FBPE C.A. No. 9813

PRODUCT:	IPD ALUMINUM LITE FRAME ASSEMBLY
PART OR ASSEMBLY:	TYPICAL ELEVATION, DESIGN PRESSURES & GENERAL NOTES

REVISIONS	
NO.	DATE
2	9/26/17
1	1/27/15
	UPDATE TO 6TH ED. (2017) FBC
	UPDATE TO 5TH ED. (2014) FBC
	JK
	JK
	BY

DATE:	12/20/12
SCALE:	N.T.S.
DWG. BY:	AL
CHK. BY:	LFS
DRAWING NO.:	FL-14512.3
SHEET	1 OF 2

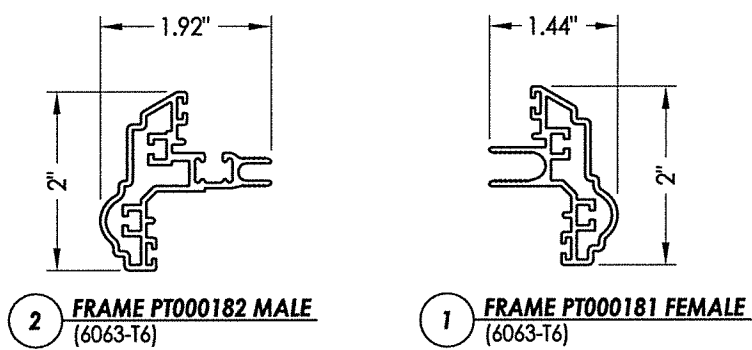
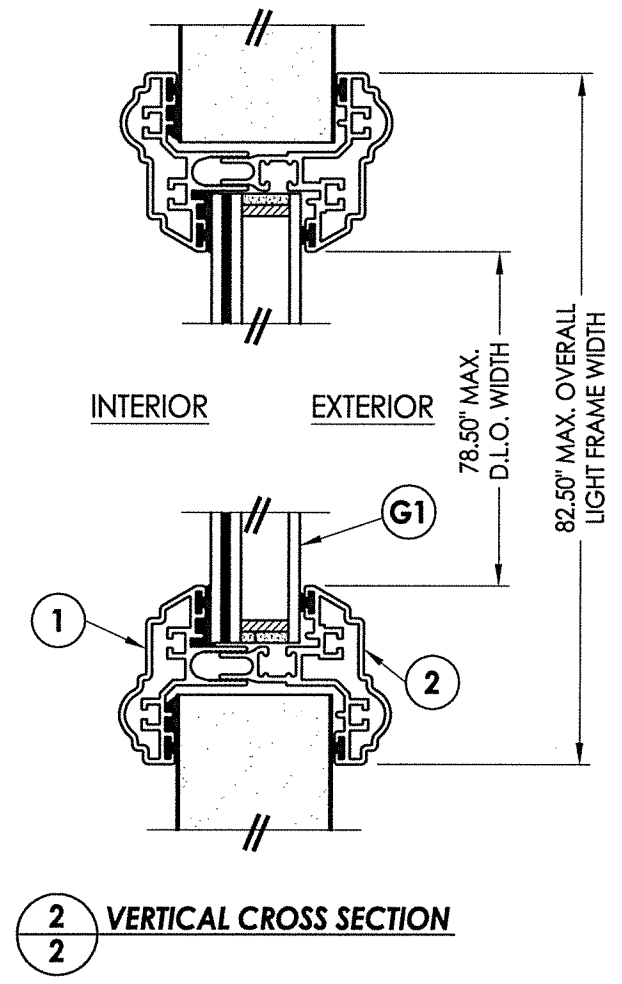
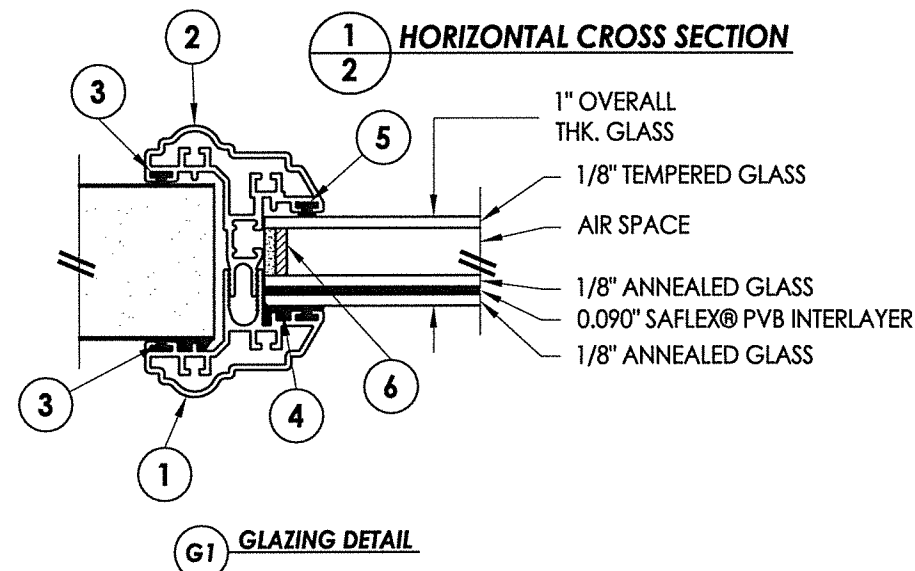
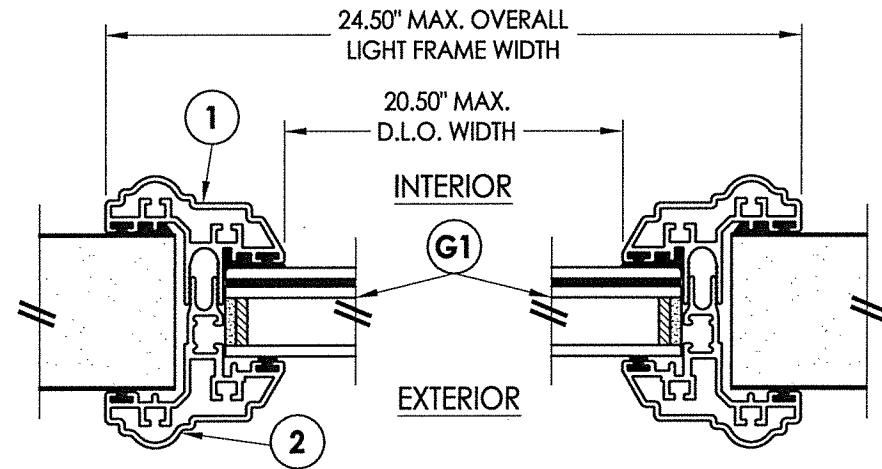
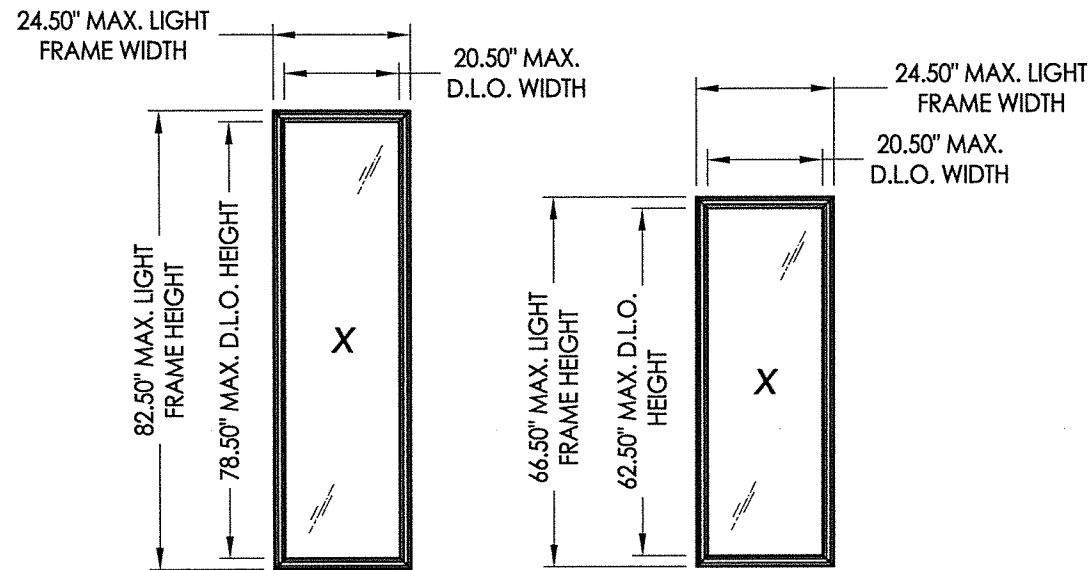

SPECIFICATION FOR DOOR AND SIDELITE PANELS:

THE IDP, INC. "ARMOR-GARD" DOORGLASS ASSEMBLY COMPONENT IS APPROVED UNDER THIS STATEWIDE PRODUCT APPROVAL. THE SINGLE GLAZED DOOR SYSTEM OR SIDELITE SYSTEM SHOWN ARE UNDER SEPARATE CURRENT STATEWIDE PRODUCT APPROVALS (MAXIMUM PANEL SIZE OF 35.75" WIDE & 95.75" HIGH). THE DOOR AND SIDELITE MUST MEET THE FOLLOWING MINIMUM REQUIREMENTS TO BE QUALIFIED WITH THIS DOORGLASS COMPONENT:

I. STEEL DOOR, SWINGING TYPE (1-3/4" MIN THICK PANEL):

1. BOTTOM RAIL: 0.020" MIN. THICK STEEL OR BETTER
2. STILE: 1.715" X 1.000" (WOOD STILE)
3. TOP RAIL: 1.715" X 1.000" (WOOD RAIL)
4. FOAM CORE: APPROVED 2-2.5 LB/FT³ DENSITY URETHANE OR 2.0 LB/FT³ DENSITY POLYSTYRENE, COMPLYING TO FBC.

II. STEEL FIXED SIDELITE (1-3/4" MIN. THICK PANEL):

1. TOP & BOTTOM RAIL: 1.715" X 1.000" (WOOD RAIL)
2. STILES: 1.715" X 1.000" (WOOD STILE)
3. FOAM CORE: APPROVED 2-2.5 LB/FT³ DENSITY URETHANE OR 2.0 LB/FT³ DENSITY POLYSTYRENE, COMPLYING TO FBC.

III. FIBERGLASS DOOR. (WOOD EDGE, 1-3/4" MIN THICK PANEL):

1. HINGE STILE: OSB 1.100" X 1.450"
2. LATCH STILE: OSB 3.780" X 1.450"
3. STILE CAP: HARDWOOD 0.372" X 1.450"
4. TOP RAIL: COMPOSITE 1.450" X .940"
5. BOTTOM RAIL: COMPOSITE 1.450" X .800"
6. FOAM CORE: APPROVED 2-2.5 LB/FT³ DENSITY URETHANE OR 2.0 LB/FT³ DENSITY POLYSTYRENE COMPLYING TO FBC.

IV. FIBERGLASS FIXED SIDELITE. (WOOD EDGE, 1-3/4" MIN THK. PANEL):

1. STILE: COMPOSITE 1.186" X 1.620"
2. TOP RAIL: COMPOSITE 1.620" X 1.125"
3. BOTTOM RAIL: COMPOSITE 1.620" X 1.066"
4. FOAM CORE: APPROVED 2-2.5 LB/FT³ DENSITY URETHANE OR 2.0 LB/FT³ DENSITY POLYSTYRENE COMPLYING TO FBC.

V. DOOR & SIDELITE SKINS

1. STEEL DOOR AND SIDELITE SKIN 0.020" THK.
2. FIBERGLASS DOOR SKIN 0.125" THK.
3. FIBERGLASS SIDELITE SKIN 0.083" THK.

BILL OF MATERIALS		
ITEM	DESCRIPTION	MATERIAL
1	FRAME PT000181 FEMALE (6063-T6) BY TAYLOR BLDG PRODUCTS	ALUM.
2	FRAME PT000182 MALE (6063-T6) BY TAYLOR BLDG PRODUCTS	ALUM.
3	GLAZING COMPOUND LORD 410/19	ACRYLIC
4	STRUCTURAL SILICONE DOW #995	SILICONE
5	NON STRUCTURAL SEALANT	BUTYL
6	1/2" NON-GROOVE SWIGGLE W/ DELCHEM#80 POLYSULFIDE 1/8" BACKFILL	-

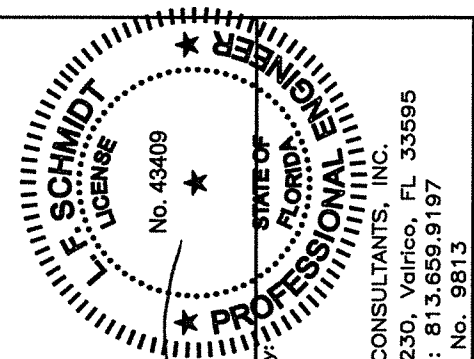

Documents Prepared By:
Lyndon F. Schmidt
P.E. No. 43409

R.W. BUILDING CONSULTANTS, INC.
P.O. Box 230, Valrico, FL 33595
Phone No.: 813.659.9197
FBPE C.A. No. 9813

PRODUCT:	IPD ALUMINUM LITE FRAME ASSEMBLY	
PART OR ASSEMBLY:	CROSS SECTIONS, GLAZING DETAIL, & B.O.M.	
DATE	NO.	BY
9/26/17	2	JK
1/27/15	1	JK
		BY
REVISIONS		
DATE:	12/20/12	
SCALE:	N.T.S.	
DWG. BY:	AL	
CHK. BY:	LFS	
DRAWING NO.:	FL-14512.3	
SHEET	2 OF 2	